

**NOTES:**

1. SHAFT STIFFNESS:  
THE STIFFNESS OF THE SHAFT BETWEEN THE MAIN ROTOR CORE  $\phi$  AND SHAFT EXTENSION  $\phi$  IS  $87.81 \times 10^6$  kgcm/radian (STIFFENING EFFECT OF MAIN ROTOR CORE IS NOT INCLUDED IN THIS FIGURE).

2. SHAFT PROPERTIES:  
MINIMUM YIELD : 260MPa  
MINIMUM ULTIMATE TENSILE STRENGTH : 530MPa  
SHAFT MATERIAL IS APPROVED BY MARINE AUTHORITIES WHEN APPROPRIATE.

3. MAXIMUM RECOMMENDED VIBRATORY STRESS LEVEL IN THE SHAFT IS  $34.47 \times 10^6$  N/m<sup>2</sup> FOR SPEED RANGE OF 0.95 TO 1.1 X NOMINAL SPEED AND  $68.94 \times 10^6$  N/m<sup>2</sup> FOR RUN THROUGH CONDITIONS, FOR INDUSTRIAL MACHINES.

4. FOR MARINE AUTHORITIES, THEIR APPROPRIATE RULES WILL APPLY.

5. CUMMINS GENERATOR TECHNOLOGIES LTD SHOULD BE NOTIFIED OF ANY ROTORS NOT COMPLYING WITH THESE RULES. CUMMINS GENERATOR TECHNOLOGIES LTD BALANCE ROTORS TO COMPLY WITH INTERNATIONAL STD ISO 1940 GRADE 2.5 AND BS 6861 PART 1 GRADE 2.5.

6. FOR UNBALANCED MAGNETIC PULL (U.M.P) FORCES PLEASE CONTACT CUMMINS GENERATOR TECHNOLOGIES LTD.



**Part Number: A072D467**

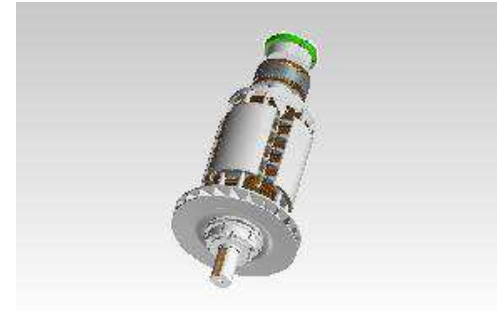

3D image provided when available for visual reference only.

Change Notice	CN00113556	Alternates	
Manufacturer Part (MEP)	No	Usage	Production Only
Release Phase Code	Production (P)	Drawing Specification	Number: DS47105146
External Regulations	No External Regulation		Revision: C

**Drawing Revision Information**

<b>Description of Change(s)</b> Note: Change information is provided for reference only and does not supersede the drawing's primary content.
SEE CHANGE NOTICE.
PRODUCTION RELEASE

**Drawing Authorization**

Drafter	Pratik Vijay Patil	Date	16NOV2023
Checker	Sneha Pundlikrao Bondlewad	Date	16NOV2023
Approver	Matthew Hammond	Date	16NOV2023

Document Generated: 16NOV2023 15:18 GMT