

Cummins Generator Technologies		
DIMENSIONS ARE IN: MILLIMETERS [] ARE IN: -		
DRAWING SPECIFICATION DESCRIPTION S6LID-H, 4P, 1B		CAD SYSTEM PTC® Creo® Parametric

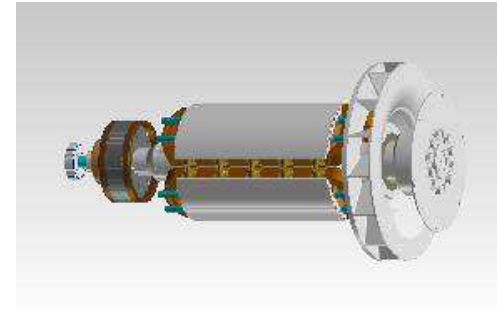

Part Number: A057G660

Change Notice	CN00077355	Alternates	
Manufacturer Part (MEP)	No	Usage	Production Only
Release Phase Code	Production (P)	Drawing Specification	Number: DS47118976
External Regulations	No External Regulation		Revision: A



3D image provided when available for visual reference only.

Drawing Revision Information

<p>Description of Change(s) Note: Change information is provided for reference only and does not supersede the drawing's primary content.</p>
<p>MINOR AMENDMENTS</p> <p>ADMINISTRATIVE CHANGE(S) TO PART ATTRIBUTES, BILL OF MATERIAL, OR ASSOCIATED SPECIFICATIONS.</p>

Drawing Authorization

Drafter	Aishwarya Rajaram Shelar	Date	10JAN2023
Checker	Kuldeep Dilip Pawar	Date	10JAN2023
Approver	NO APPROVAL REQUIRED	Date	

Document Generated: 10JAN2023 10:12 GMT