



Application Guidance Notes: Technical Information from STAMFORD | AvK

## AGN 173 – Residual Voltage and Residual Magnetism

### DISCUSSION

Application Engineering have been asked to provide an explanation to the observed differences in residual voltage levels between similar alternators, that have been manufactured at different locations, when the alternators are running without excitation.

The following explanation starts with a look at the fundamental functions of an alternator, moving on to analysis of the magnetic circuits and finally an answer to the posed question.

### Explanation: Part 1 – Fundamental Functions

First consider the basic brushless ac generator (alternator) block diagram:

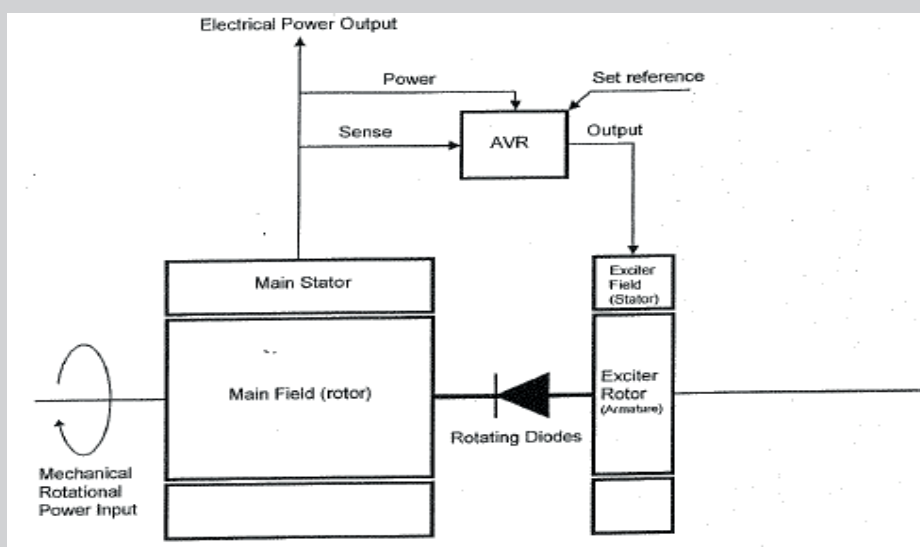

Then consider the normal mode of excitation control described below, which assumes the alternator is running at speed, the AVR is 'active' and therefore it can be said that the alternator is 'excited'.

A dc output from the AVR applies a voltage to the exciter field windings, current flows, the field windings produce ampere-turns, resulting in a magnetic flux being generated in the fields iron circuit (stator lamination steel) and the resulting field produces a magnetic flux, prompting the following conditions:

- Magnetic flux crosses the exciter air gap
- A voltage is generated in the exciter rotor (armature) winding
- The exciter's 3-phase ac output is converted by the rotating rectifier
- The rectified dc voltage is applied to the main rotor winding
- A corresponding dc current flows through the main rotor winding
- Main rotor ampere-turns produce a magnetic flux
- This flux emanates from the rotor pole faces crossing the air gap
- A voltage is generated within the main stator winding
- AVR senses the magnitude of the induced stator winding voltage
- AVR compares 'sensed' voltage level with 'set' voltage level
- AVR adjusts applied voltage to exciter field to achieve 'sensed' voltage level matching 'set' voltage level.

### **Explanation: Part 2 – Magnetic Circuits**

Consider the below 'hysteresis loop' for ferromagnetic material as typically used for the lamination steel within an alternator.

- The vertical B axis is flux density.
- The horizontal H axis is the magnetising force, or magnetic field intensity.

The initial magnetization curve from O to D is not shown. This would be a situation equivalent to an initial 'flash-up' of a new alternator, or an in-service 're-flashing of the exciter field'.

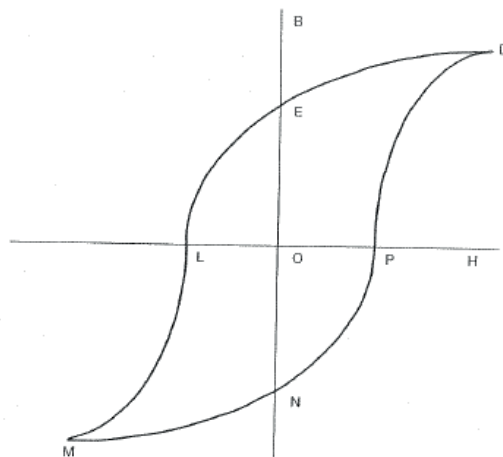

Note how once magnetised, the lamination steel retains a level of stored magnetic field strength (O to E) and is commonly referred to as the materials **remanence**.

As the exciter field winding is supplied by a dc supply, the only relevant portion of the above curve is the top right hand quadrant.

However, when the alternator is operating, the dynamics of the operation of the exciter field generated magnetic flux, and the 'armature reaction' effects resulting from current flowing within the exciter rotor (armature) windings will constantly be de-magnetising the exciter field's magnetic circuit. This means that in service, the exciter field lamination steel will never have sufficient remanence to provide the alternator with a strong enough magnetic field to meet even the alternator's No-Load excitation requirements. Thereby requiring the AVR to always provide current to the exciter field winding (ampere-turns), thereby making a positive contribution to the exciter's operational magnetic flux level.

The magnetic properties of the exciter field lamination steel are carefully considered during the design stage of the alternator, in order to ensure there will be sufficient remanence to ensure that the alternator will have a level of residual voltage sufficiently high enough to 'wake-up' the AVR, and so ensure reliable self-excitation of alternator, where the SX / SA / AS type AVR's are used.

Remanence is the result of magnetic domains within the steels structural molecules remaining in magnetic polarisation alignment. These magnetic domains will become un-aligned if:

- The lamination steel is subjected to imposed vibration or mechanical shocks.
- The alternator is run-down with load still connected and therefore armature reaction demagnetises the steel.

### **Explanation: Part 3 – Alternators fitted with PMG and Digital / MX / MA type AVRs**

Here the PMG provides the AVR with the 'wake-up' power supply and therefore these 'separately-excited' alternators are not dependent upon exciter field remanence properties.

### **CONCLUSION**

To answer to the posed question, comparisons between alternators from different manufacturing batch numbers, or indeed different manufacturing sites, may well result in observed different levels of 'residual voltage'. This is due to variability in the installed exciter field lamination steel's B-H curve characteristic.

### **Self-excited Alternators**

If the alternators in question are fitted with SX, SA, or AS type AVRs, then such concerns maybe well founded, if the level of residual voltage is of a low level and therefore introduces concern that the alternator may not self-excite.

In such a situation, the alternator should be run under rated No-Load conditions and then stopped. The level of residual voltage should again be measured and this value noted and compared with published data for that type of alternator.

### **Separately-excited Alternators**

If the alternators are fitted with a PMG, then as explained above, the exciter field's remanence and resulting level of residual voltage will not affect the alternator's ability to reliably self-excite every time the unit is started and run-up to speed.

### **System check**

Typically, an alternator will produce 10% to 20% of rated output voltage as a residual voltage level. If the alternator is a high voltage (HV) type, then some 2kV could be present at the output terminals. Accidental contact with such a voltage level must be avoided.

When low levels of residual voltage are measured, they can be a warning that the alternator has an internal fault. The fault may be one or more of the following:

- A failed rotating diode.
- An indication of a stator winding problem, and here the measured voltage levels will not be balanced in the typical L-L-L, and L-N relationship.

[stamford-avk@cummins.com](mailto:stamford-avk@cummins.com)

[www.stamford-avk.com](http://www.stamford-avk.com)



Copyright 2024, Cummins Generator Technologies Ltd. All rights reserved.  
Cummins and the Cummins logo are registered trade marks of Cummins Inc.  
STAMFORD and AvK are registered trademarks of Cummins Generator Technologies Ltd.

**STAMFORD | AvK** <sup>TM</sup>  
POWERING TOMORROW, TOGETHER