

## AGN 071 – Load Sharing with Quadrature Droop

### LOAD SHARING

While the active power (kWe) sharing between Generating Sets during parallel operation is governed by the engine, the reactive power (kVAr) sharing is controlled by the alternator's control system. There are various recognised load sharing methods in the generator industry, such as isochronous load sharing, cross-current compensation and quadrature droop load sharing.

Quadrature droop load sharing is the standard kVAr load sharing method utilised by Cummins Generator Technologies. For AvK and STAMFORD alternators, quadrature droop load sharing requires a Droop Current Transformer (CT) to be fitted on one of the alternator's output phases. For AvK and STAMFORD alternators fitted with digital Automatic Voltage Regulator's (AVR), the quadrature droop should be programmed on installation. For STAMFORD alternators fitted with analogue AVRs, the CT secondary winding should be connected to the AVR droop S1 - S2 inputs.

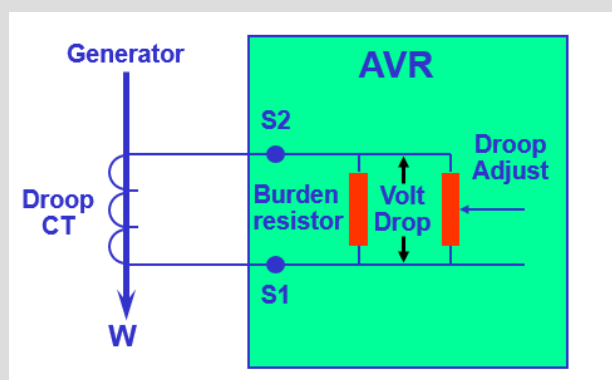

Figure 1: Example of Droop CT connection to the AVR

The current signal from the Droop CT secondary winding is converted to a voltage signal across a burden resistor within the AVR. This voltage signal is then added vectorially to the AVR sensing voltage so that the AVR will be “tricked” to droop the voltage by adjusting the excitation levels accordingly, in proportion to the levels of load current and power factor. It is important to have the droop CT on the same phase and the same AVR droop setting for all paralleled alternators (usually 3% at 0.8pf) to ensure proportional kVAR sharing among the Generating Sets.

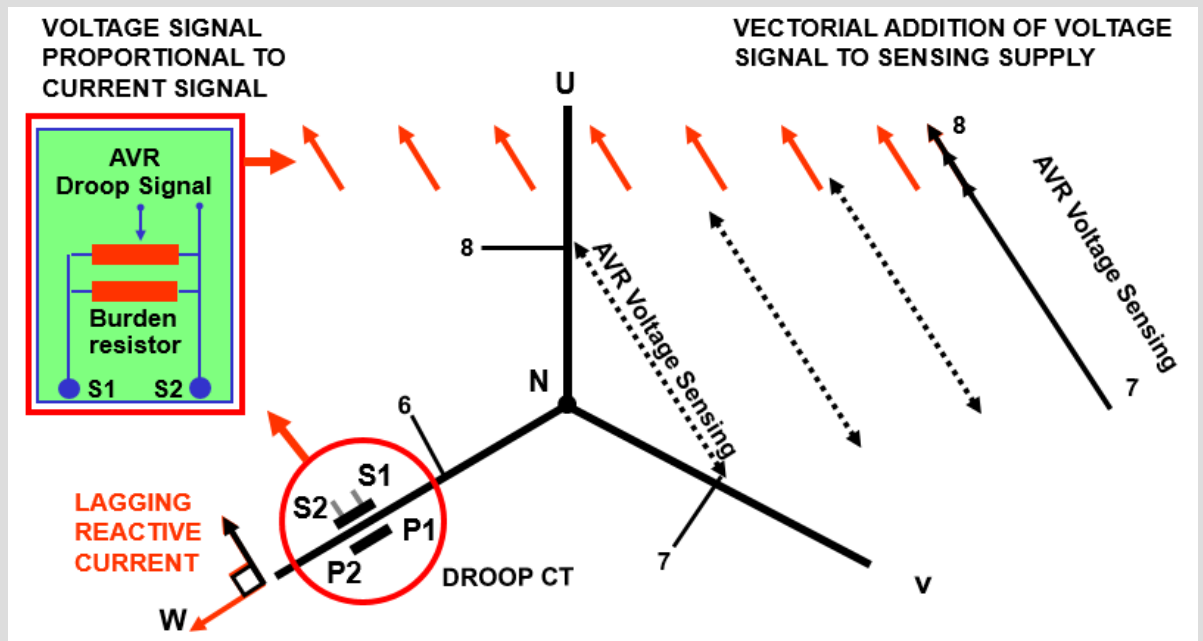

Figure 2: Example of vectorial addition of droop signal to the AVR sensing voltage

Because the percentage ‘droop’ of the output voltage is related mainly to the reactive component of the load current, the droop is negligible when the load current is at unity power factor. For this reason any attempt to check the operation of the ‘droop’ characteristic by testing with a resistive load bank will not result in any observed ‘droop’ in the Generating Set’s output voltage.

## SETTING THE QUADRATURE DROOP AND POLARITY CHECK

The procedure for setting up the analogue AVR droop pot is explained here. As most Generating Set manufacturers only have a resistive load test capability, a method to check the droop polarity has evolved.

1. Run the Generating Set with a resistive load of at least 20% of the Generating Set’s rated output current, but obviously, the greater the percentage load the better the chance of an accurate set-up.
2. Record the load current and with the load still being supplied, measure the a.c. voltage across AVR terminals S1 - S2 (the droop CT secondary) and record this voltage – the voltage should be in the region of 0V – 5V.
3. Refer to the appropriate graph for the alternator’s AVR type (see graphs below) and by starting on the X axis with the recorded S1 - S2 voltage, then up to the appropriate sloping percentage load line, then horizontal to the Y axis, a pot % setting is given for

the alternator droop circuit to give 5% droop for rated load at zero power factor (approximately 3% at 0.8pf). A selection of graphs are included within this AGN.

4. Having set the AVR droop pot, some indication that the alternator will droop and not rise is now possible by the following test.
5. Take two 4700 $\mu$ F electrolytic capacitors and two diodes (typical electronic circuit board type). Connect the capacitors in series with the two negative ends joined together and therefore, the positive leads of each capacitor are now the ends of the series chain. The two capacitors are connected in this way because individually, they are polarity sensitive and the next instruction involves an a.c. voltage. Connection diagram for capacitors and diodes included within this AGN.
6. With the Generating Set running and the test load connected, use a safe, workmanlike method to connect the 'series capacitors network' across the AVR S1-S2 terminals. When the capacitors are connected, observe that the generator output voltage does droop and **not** rise.
7. If the output voltage does rise then the Droop CT secondary S1 -S2 must be reversed.

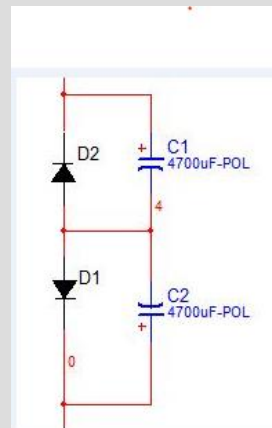

Figure 3: Capacitor-diode circuit diagram for droop CT polarity check

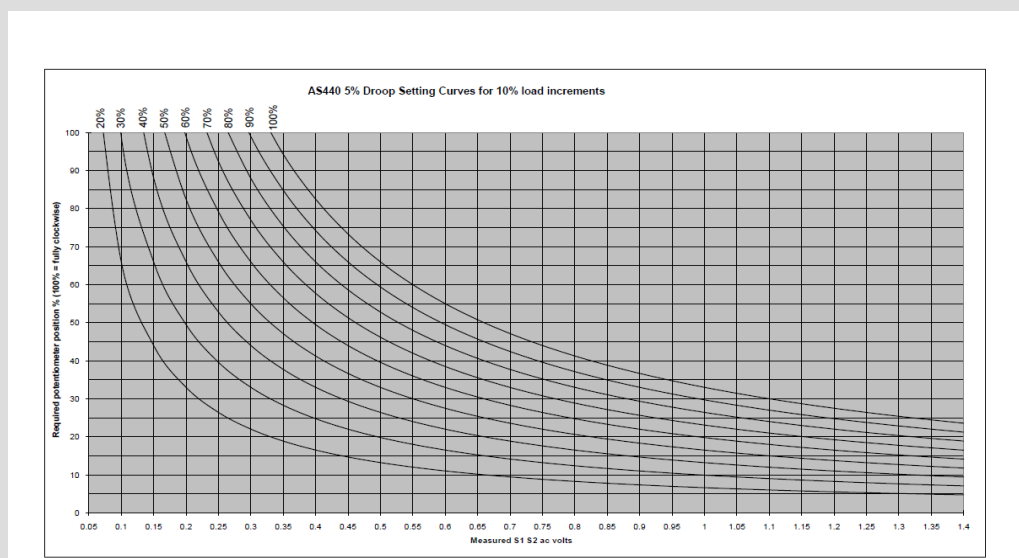

Figure 4: AS440 droop setting curves at various load

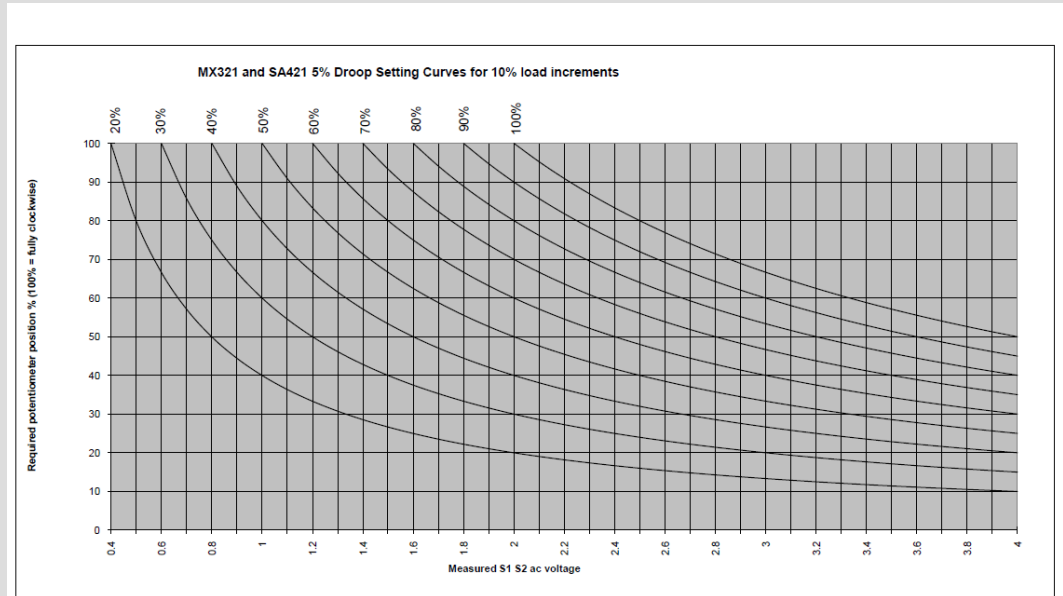

Figure 5: MX321 and SA421 droop setting curves

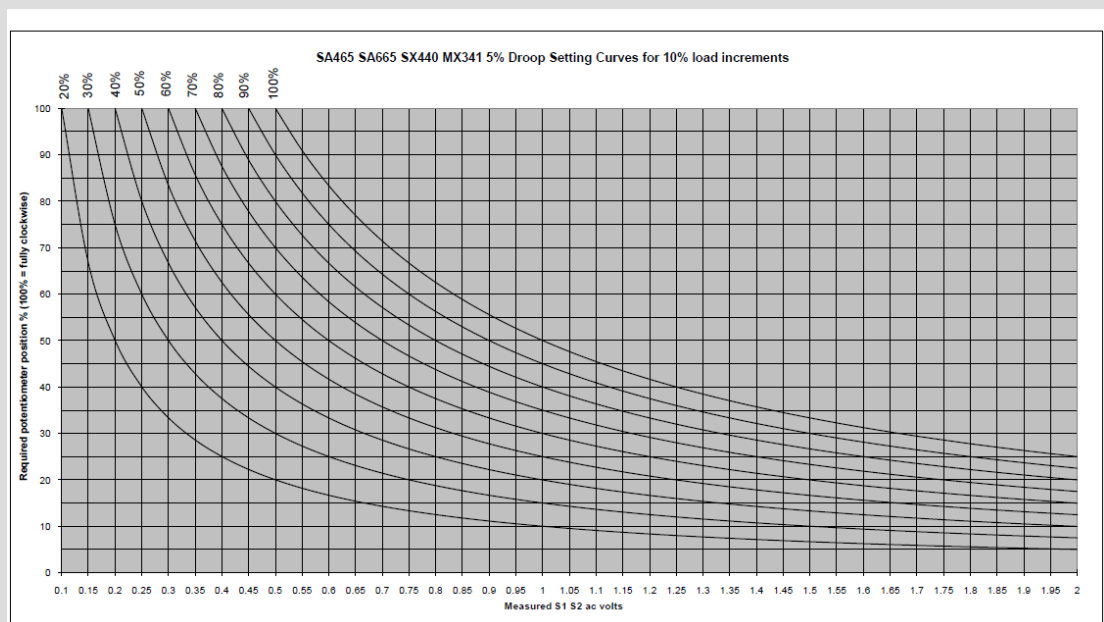

Figure 6 SA465, SA665, SA440, MX341 droop setting curves

## DROOP CT SELECTION

The analogue AVRs used on STAMFORD alternators can accept a maximum droop input current of 0.33A and the recommended minimum droop input current is 0.225A. This means that the Droop CT secondary winding must generate between 0.225A and 0.33A at the rated alternator current in order for the AVR droop circuit to work correctly.

The digital AVRs usually have a maximum droop input current of 1A.

The Droop CT is factory fitted and the selection of Droop CT is based on the alternator rating and the type of AVR used. The Applications Engineering department should be consulted if there is a need to select Droop CT post-delivery of the alternator. Contact [applications@cummins.com](mailto:applications@cummins.com).