

Application Guidance Notes: Technical Information from Cummins Generator Technologies

# AGN 027 - Winding and Bearing Temperature Sensors

## **INTRODUCTION**

There are three cost effective ways of detecting winding temperatures:

- Thermostats - Bi-metallic switches pre-set to a fixed temperature.
- Thermistors - Temperature sensitive resistor with pre-set operating knee point.
- RTD (Resistance Temperature Detector) - Resistive element with a linear resistance change, proportional to the temperature change.

## **BASIC CONSIDERATIONS**

Ideally, for detecting winding temperatures, the temperature sensor should be embedded within the windings in such a way that true winding temperatures are detected. This means the detecting element must be constructed of a suitable shape for inclusion within the winding slot and be robust enough to cope with the stator winding impregnation process.

It is also most important that the temperature sensor is small enough to be embedded within the winding slot, without affecting the amount of copper winding wire space available to such an extent that the winding section has to be reduced resulting in a reduction of the alternator's normal output rating.

## **Thermostats**

Some Thermostat units are manufactured within a tubular body, which is susceptible to being misshaped during the stator winding process, often resulting in a change to the operating temperature of the bi-metallic element.

It is considered prudent to have an isolated, low voltage, low current, on-inductive circuit connected to any temperature detecting element to minimise the risk any interaction or interference between the stator winding load circuit and the temperature detecting circuit.

This is achieved in an ideal way with either the Thermistor or RTD systems, but less well achieved with a Thermostat scheme.

There is always a considerable risk with Thermostats, where often, a typical single phase supply is used to energise a control relay, that the combination of the relatively high voltage system, in conjunction with the inductive nature of the relay coil, cause the thermostat contacts to be damaged by 'arcing' upon first operation.

There is also the **safety aspect** with the Thermostat system where a non-isolated, high voltage supply is used, with the risk of this supply being present within the alternator windings and terminal box during fault finding, or maintenance, which requires the control system to be switched on.

For these reasons, Thermostats are not offered as an option on STAMFORD and AvK Alternators.

## **STAMFORD AND AvK SCHEMES**

RTDs and Thermistors are offered as winding temperature detectors on STAMFORD and AvK Alternators. RTDs or Thermistors could be fitted, not both. Thermistors may be used for detecting winding temperatures only. RTDs may be used for detecting winding temperatures or bearing temperatures.

### **Resistance Temperature Detector (RTD)**

The RTD system employs PT 100 solid state devices, equi-spaced around the stator windings. They are installed as sets of three, one per phase, in the winding slots during manufacture. It is possible to install more than one set on larger alternators.

The RTDs are connected to a programmable modular control unit, which is often a function of the Generating Set control unit and is not supplied by Cummins Generator Technologies. These modular units are available offering many features including display of actual operating temperature and programmable alarm and shutdown temperatures.

An RTD has a linear increase in resistance directly proportional to the detected temperature. The description PT100 refers to a Positive Temperature coefficient, based on the device having a resistance of 100Ω at 0°C, with a linear increase of some 0.385Ω for every 1°C increase.

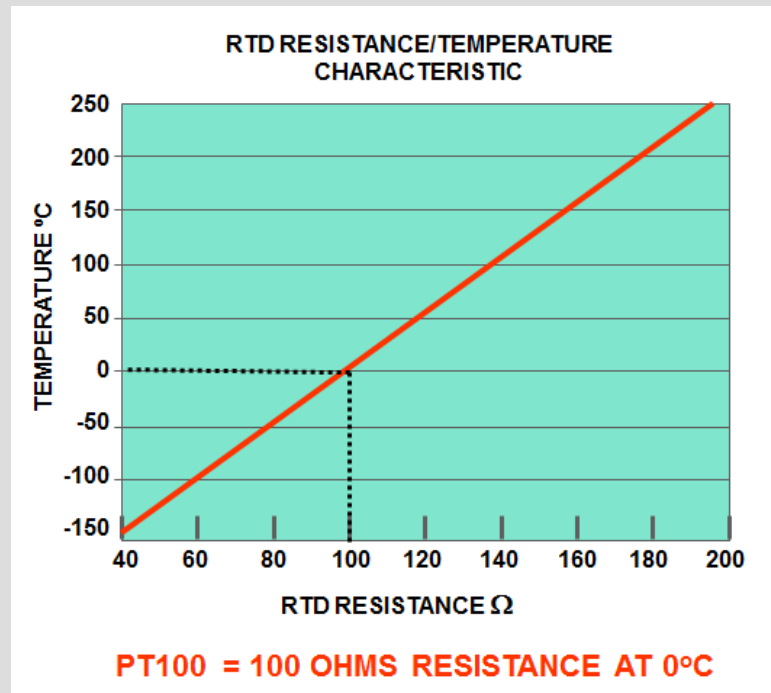

RTDs may be used for detecting temperatures in the stator winding, and they may also be used to detect temperatures in the alternator's bearings. Bearing RTDs are also type PT 100 devices, but of a different design to those used in stator windings.

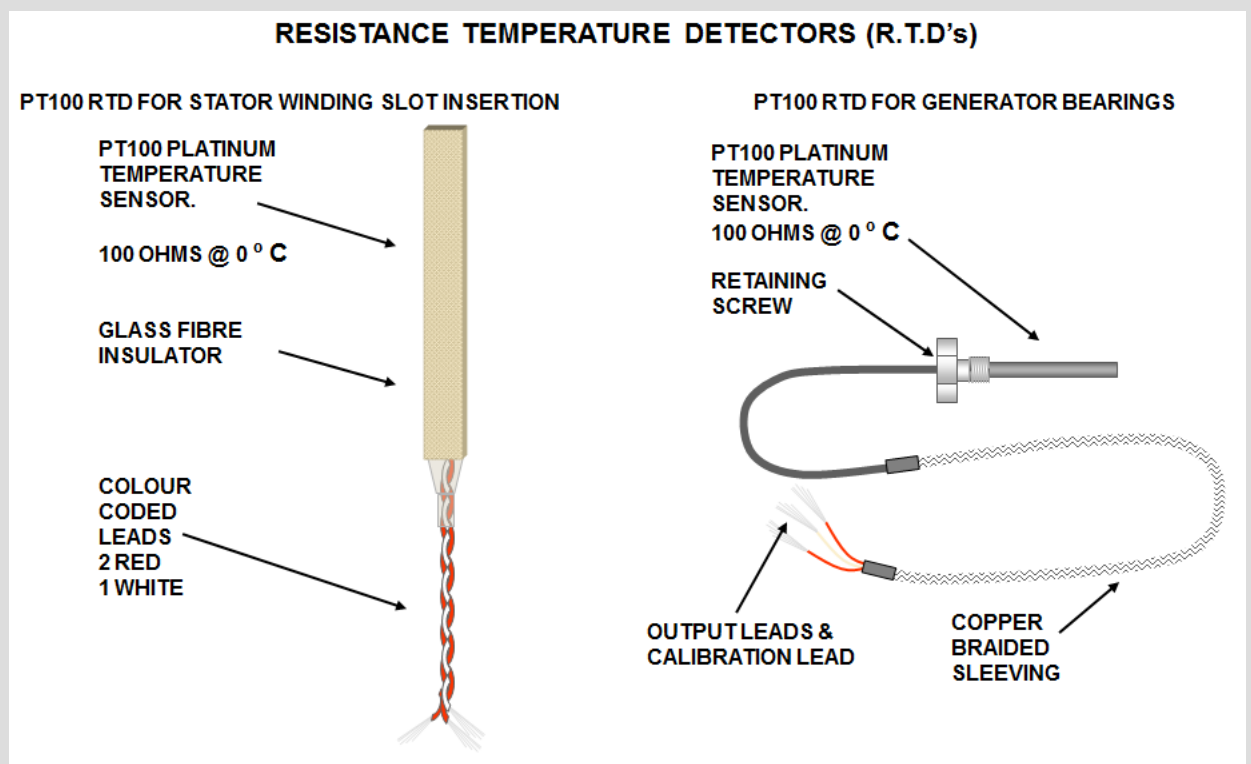

## Winding RTDs

Winding RTDs are embedded within the stator winding assembly in groups of three, equi-spaced such that each one is detecting the temperature of a different phase winding.

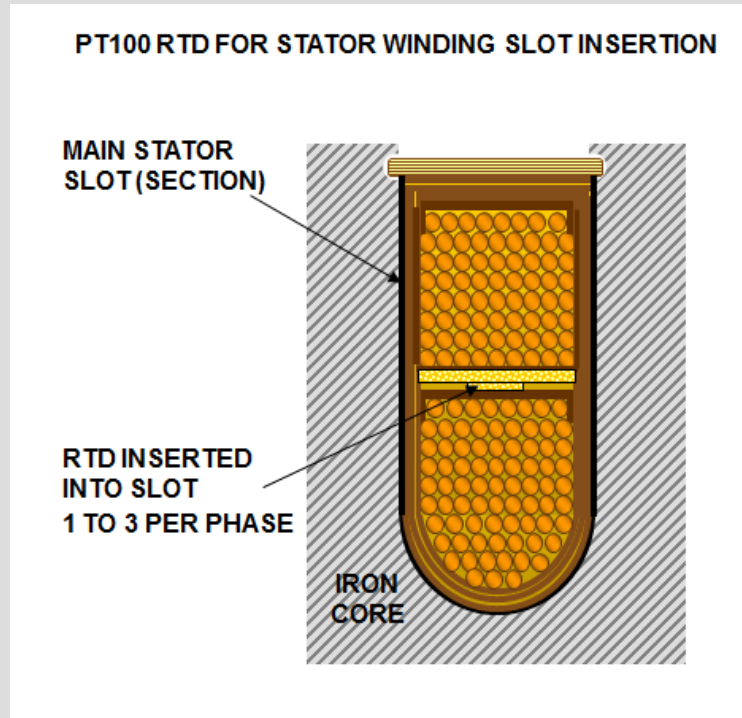

An alternators' winding temperature will be directly related to the kVA and power factor of the load, and so assuming an ambient of typically 30degC, an alternator will have 'roughly' the following component temperatures.

### Winding Temperatures

**[Class H temperature rise rating of 125degC] + [allowance for local hotspot of 15degC] + [local ambient temperature, assumed to be 30degC].** The maximum expected running temperature =  $125 + 15 + 30 = 170\text{degC}$ .

To provide warning of the maximum expected temperature, we suggest RTDs used for ALARM be set at 170degC. For SHUTDOWN, we suggest they should be set at  $170 + 20 = 190\text{degC}$ .

For marine alternators with Class H temperature rise ratings, to provide warning of the maximum expected temperature, we suggest RTDs used for ALARM be set at 165degC. For SHUTDOWN, we suggest they should be set at 185degC.

**[Class F temperature rise rating of 105degC] + [allowance for local hotspot of 10degC] + [local ambient temperature, assumed to be 30degC].** The maximum expected running temperature =  $105 + 10 + 30 = 145\text{degC}$ .

To provide warning of the maximum expected temperature, we suggest RTDs used for ALARM be set at 145degC. For SHUTDOWN, we suggest they should be set at  $145 + 20 = 165\text{degC}$ .

There is no change in suggested settings for marine alternators with Class F temperature rise ratings.

**[Class B temperature rise rating of 80degC] + [allowance for local hotspot of 10degC] + [local ambient temperature, assumed to be 30degC] = The maximum expected running temperature =  $80 + 10 + 30 = 120\text{degC}$ .**

To provide warning of the maximum expected temperature, we suggest RTDs used for ALARM be set at 120degC. For SHUTDOWN, we suggest they should be set at  $120 + 20 = 140\text{degC}$ .

There is no change in suggested settings for marine alternators with Class B temperature rise ratings.

All commissioning engineers should establish the real running temperatures under site load conditions and then programme the temperature sensing module for ALARM and SHUTDOWN temperatures based on real measured and witnessed running temperatures during commissioning trials and signed-off parameters, including the recorded thermal levels of all thermally monitored components, fluids and gasses.

### Bearing RTDs

Bearing RTDs are normally fitted to the bearing cartridge, however; they are fitted to the end bracket on S4 and S5 alternators.

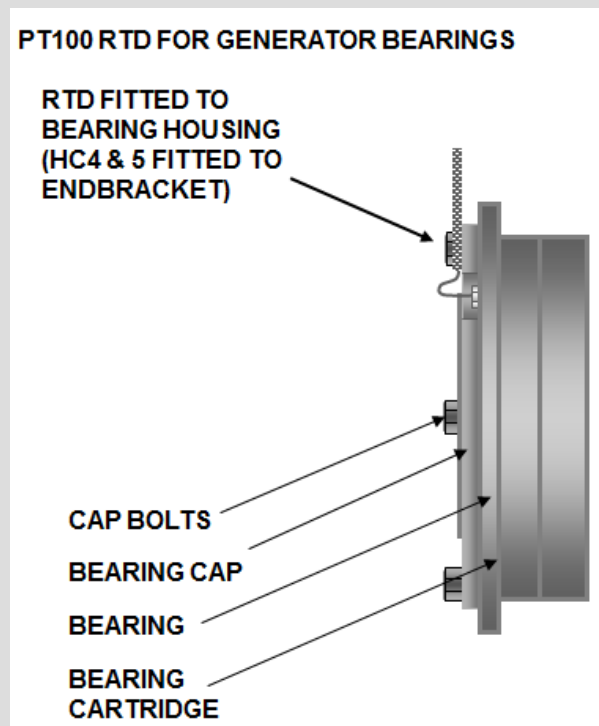

The temperature of a bearing is never a product of the bearing friction and generated heat, rather a temperature associated with the stator and rotor assemblies and the conducted heat from these two hot assemblies through the frame and end brackets into the bearing housing. In fact a Drive End (DE) bearing's temperature is often governed by conducted heat from the engine components through the flywheel housing/alternator adaptor/ DE bracket assembly.

### **Bearing Temperatures:**

Typically under the above assumed 30degC ambient and a Class H temperature rise rated load condition, the outside surface of the alternator frame will run at around 70degC. Such a frame temperature will result in a bearing housing temperature also around 70degC.

Usual recommendation for bearing RTD's is for ALARM to be set at 90degC, and SHUTDOWN set at 105degC.

**Note 1.** Quite often the DE bearing RTD will indicate 100degC if the Generating Set is stopped too quickly after a long full-rated load run. Usually this is because the Generating Set housing/canopy/container is not ventilated - doors opened, or forced vent system - for a short period of time after a hot Generating Set has been shut down. A prolonged 'cool-down' period will always be beneficial for component temperature equalisation, but often not acceptable to engine manufacturer.

**Note 2.** A hot shutdown in a 'non-additionally' ventilated Generating Set housing promotes a micro-climate of very high humidity [RH%] and this 'attacks' winding insulation systems.

### **Thermistors**

Three thermistors embedded within a stator winding - series connected - offer a low-cost temperature detection system, which when used in conjunction with a control module, provide a basic protection scheme for the prevention of overheating a stator winding. Thermistors are positive temperature coefficient resistors - low resistance when detecting low temperatures and high resistance (open circuit) when above the tripping temperature. No adjustment is possible.

The resistance of the thermistor will increase very rapidly (equal to contacts opening) when the switching temperature is reached. The resistance of the thermistor will then decrease (equal to contacts closing) when the temperature reduces below the switching temperature. By connecting the thermistors in series, a 24V dc circuit is created that will detect excessively high temperatures in the stator core pack.

Thermistors are offered as sets of three, equi-spaced around the stator windings, one per phase and each set connected to their individual modular Thermistor Control Unit, which incorporates a volt free change-over contact, for inclusion into the Generating Set control scheme. The Thermistor Control Unit is simply a switching device that provides a 'Go NoGo' signal to the Generating Set control system.

# Thermistor Positive Temperature Coefficient Resistor

**TR = Switching Temperature**

Thermistor Test Voltage  
must not exceed 2.5 VDC.

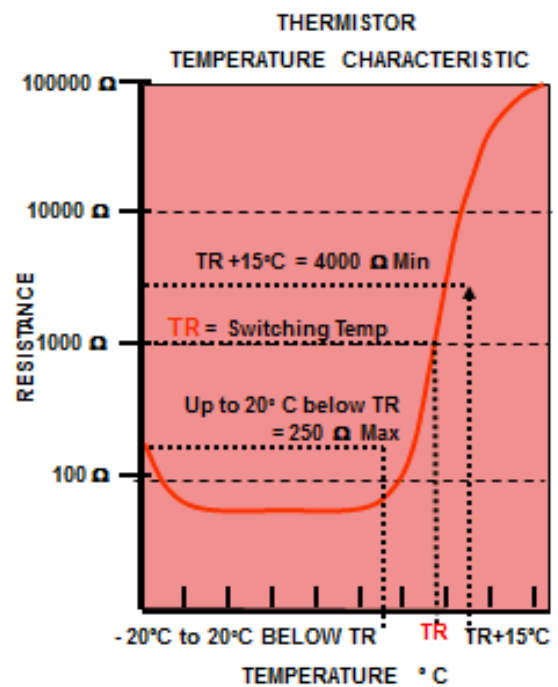

Typically, two of the above described thermistor schemes are incorporated, a system which operates at just above expected normal rated operating conditions and this scheme activates a control system function for triggering an ALARM.

A second scheme comprised of a second control module connected to three series connected thermistors with a trigger temperature of some 10°C to 20°C above the ALARM system devices which activate a controlled SHUTDOWN.

The Thermistor Control Unit is supplied loose for the Generating Set manufacturer to decide where it is to be installed - usually in or adjacent to the Generating Set controller. Installation in the alternator terminal box is not advised because of the radial heat effect from the alternator.

Thermistors with various operating temperatures are available to offer individual systems enabling different temperatures to be detected for either alarm or shut down situations, for either Class 'F' or 'H' temperature rise operating temperatures. Customers should be advised of the following switching temperature. The operational effectiveness will depend on the rate of temperature rise, the delay in sensing and the switching effectiveness of the control device.

- Class F Alarm 145°C                      Class H Alarm 165°C
- Class F Trip 165°C                        Class H Trip 190°C

## Thermistors on STAMFORD Alternators

The actual thermistor values being used to achieve the above switching temperatures are summarised below and these values have been chosen based on experience gained from a series of tests with the objective of considering the whole STAMFORD product range and so a wide variation in product types.

	<u>S4, S5, S6, S7 fitted at NDE</u>			<u>UC fitted at Drive End</u>		
Class F Alarm	070-59112	Blue/black	155°C	070-59105	White/green	170°C
Class F Trip	070-59105	White/green	170°C	070-59113	White/red	180°C
Class H Alarm	070-59105	White/green	170°C	070-59113	White/red	180°C
Class H Trip	070-59113	White/red	180°C	070-59104	Grey/brown	190°C